

Nozzle Adapter Blanket

Drool Protection Worksheet

How To Order

To process an order or quote please specify the following information

Nozzle Adapter Blanket

"N"=Circumference of Nozzle

"C"=Circumference of Barrel

Blanket

"L"=Length from End of Barrel through Nozzle Band

LINE # _____ QUANTITY _____

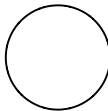
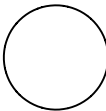
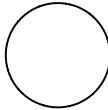
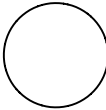
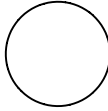
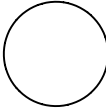
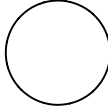
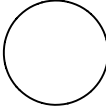
N		C		L	_____	_____
N		C		L	_____	_____
N		C		L	_____	_____
N		C		L	_____	_____

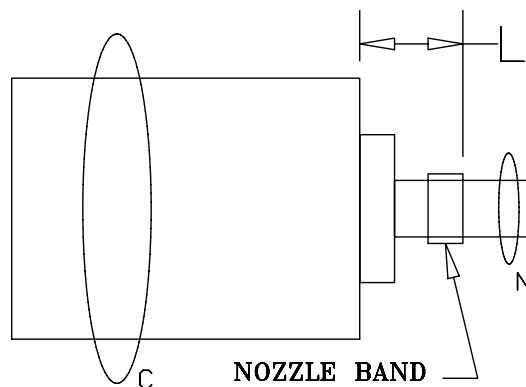
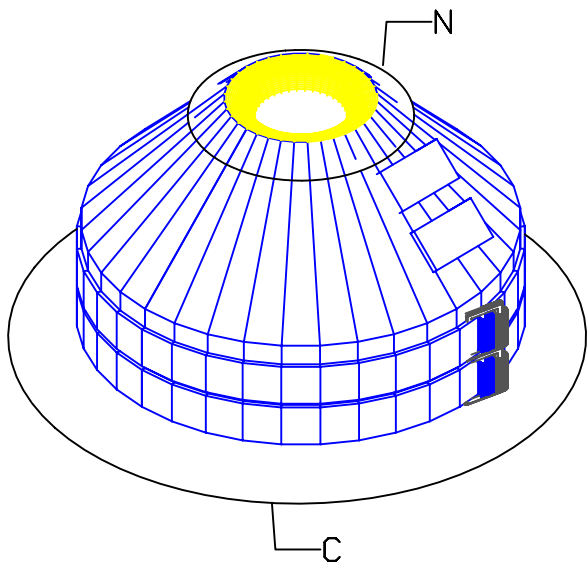

Customer Information

Contact Name _____
 Company _____
 Address _____
 City, State, Zip _____
 Telephone _____ - _____ - _____
 Fax _____ - _____ - _____

Rep/Distributor _____
 Salesperson _____
 Telephone _____ - _____ - _____
 Fax _____ - _____ - _____
 Machine Brand _____
 Tons/Ounces _____
 Temperature Range _____

Make copies from this worksheet as needed and fax your request to us. Fax (972) 436-0112.
 Do you have questions? Please call us toll free 1 (800) 657-9542 _ or E-mail us at unitherm@unitherm.com
 also visit our website at <http://www.unitherm.com>