



Line #: _____

How To Order

To process an order or quote please specify the following information

- C - Circumference of heater band and J Boxes
- W - Width between thermocouples
- Z - J-box width for gap

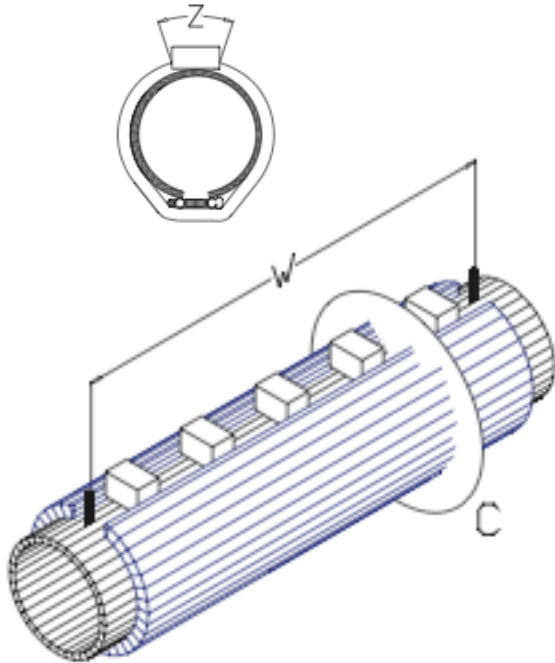

					Gap
Rear	1	<input type="checkbox"/> CSTM		<u>W</u>	<u>Z</u>
M1	2	<input type="checkbox"/> CSTM		<u>W</u>	<u>Z</u>
M2	3	<input type="checkbox"/> CSTM		<u>W</u>	<u>Z</u>
M3	4	<input type="checkbox"/> CSTM		<u>W</u>	<u>Z</u>
M4	5	<input type="checkbox"/> CSTM		<u>W</u>	<u>Z</u>
M5	6	<input type="checkbox"/> CSTM		<u>W</u>	<u>Z</u>
M6	7	<input type="checkbox"/> CSTM		<u>W</u>	<u>Z</u>
M7	8	<input type="checkbox"/> CSTM		<u>W</u>	<u>Z</u>
M8	9	<input type="checkbox"/> CSTM		<u>W</u>	<u>Z</u>
M9	10	<input type="checkbox"/> CSTM		<u>W</u>	<u>Z</u>
M10	11	<input type="checkbox"/> CSTM		<u>W</u>	<u>Z</u>
M11	12	<input type="checkbox"/> CSTM		<u>W</u>	<u>Z</u>
Front	13	<input type="checkbox"/> CSTM		<u>W</u>	<u>Z</u>

Customer Information

Company: _____
 Rep/Distributor: _____
 Contact Email: _____
 Phone Number: _____

Make copies from this worksheet as needed and fax or email your request to us.
 Fax 972.436.0112 If you have any questions please call us at 1.800.657.9542 or
 email us at unitherm@unitherm.com