

SEE OVER

# Blown Film Die

Adj Lug Hooks Qty: \_\_\_\_\_

Die Size: \_\_\_\_\_

Die Brand: \_\_\_\_\_



Line #: \_\_\_\_\_

## How To Order

To process an order or quote please specify the following information

Blankets size  
Split into multiple blankets if width is over 12"

If circumference is larger then 60"  
make multiple blankets

C - Full Circumference of die including heater bands and J-Boxes

L - Height of outer or upper lip

W - Height of die body and mandrel

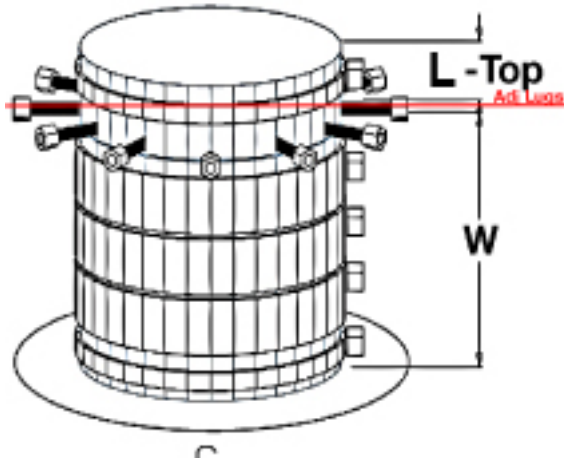

## Customer Information

Company: \_\_\_\_\_

Rep/Distributor: \_\_\_\_\_

Contact Email: \_\_\_\_\_

Phone Number: \_\_\_\_\_

Adj Lugs	Top	Qty	Material	C	W	Gap	Z
	1	1	CSTM		_____		_____
	M1	2	CSTM		_____		_____
	M2	3	CSTM		_____		_____
	M3	4	CSTM		_____		_____
	M4	5	CSTM		_____		_____
	M5	6	CSTM		_____		_____
	M6	7	CSTM		_____		_____
	M7	8	CSTM		_____		_____
	M8	9	CSTM		_____		_____
	M9	10	CSTM		_____		_____
	M10	11	CSTM		_____		_____
	M11	12	CSTM		_____		_____
	Bottom	13	CSTM		_____		_____

Make copies from this worksheet as needed and fax or email your request to us. Fax 972.436.0112 If you have any questions please call us at 1.800.657.9542 or email us at [unitherm@unitherm.com](mailto:unitherm@unitherm.com)



## How To Order

To process an order or quote please specify the following information.

- A - Full Circumference
- B - O.D Heater Length
- C - Circumference Offset
- D - Length Offset
- E - I.D. for object or blanket
- F - Offset to J Box
- G - Width of J Box
- H - Length of J Box



Rear	A		B	_____	C	_____	D	_____	E	_____	F	_____	G	_____	H	_____
M1	A		B	_____	C	_____	D	_____	E	_____	F	_____	G	_____	H	_____
M2	A		B	_____	C	_____	D	_____	E	_____	F	_____	G	_____	H	_____
M3	A		B	_____	C	_____	D	_____	E	_____	F	_____	G	_____	H	_____
M4	A		B	_____	C	_____	D	_____	E	_____	F	_____	G	_____	H	_____
M5	A		B	_____	C	_____	D	_____	E	_____	F	_____	G	_____	H	_____
M6	A		B	_____	C	_____	D	_____	E	_____	F	_____	G	_____	H	_____
M7	A		B	_____	C	_____	D	_____	E	_____	F	_____	G	_____	H	_____
Front	A		B	_____	C	_____	D	_____	E	_____	F	_____	G	_____	H	_____

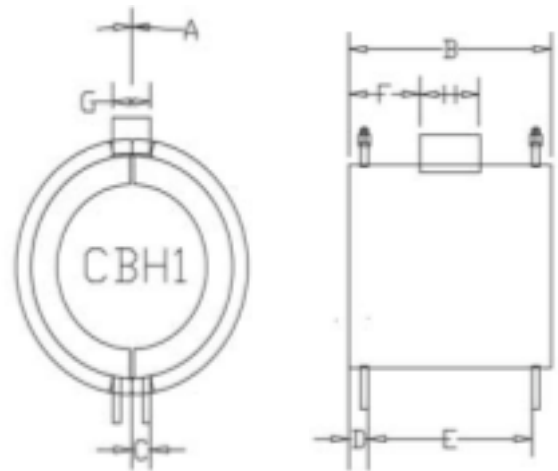

## Customer Information

Company: \_\_\_\_\_  
 Rep/Distributor: \_\_\_\_\_  
 Contact Email: \_\_\_\_\_  
 Phone Number: \_\_\_\_\_

Make copies from this worksheet as needed and fax or email your request to us. Fax 972.436.0112 If you have any questions please call us at 1.800.657.9542 or email us at [unitherm@unitherm.com](mailto:unitherm@unitherm.com)



Line #: \_\_\_\_\_

## How To Order

To process an order or quote please specify the following information

- C - Circumference of heater band and J Boxes
- W - Width between thermocouples
- Z - J-box width for gap

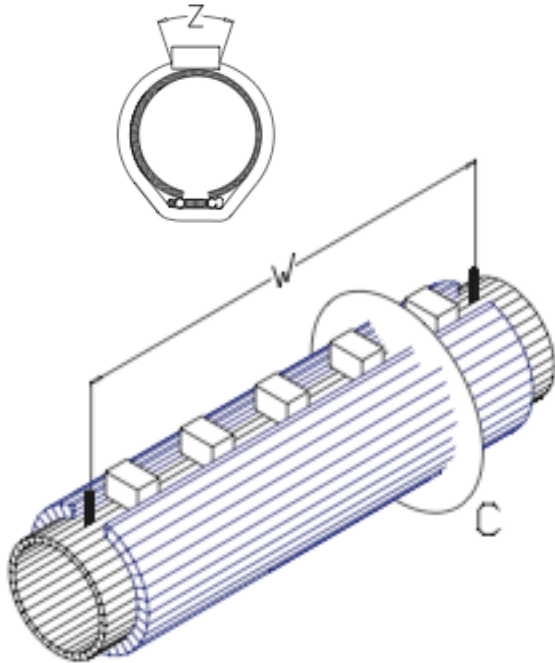

## Customer Information

Company: \_\_\_\_\_  
 Rep/Distributor: \_\_\_\_\_  
 Contact Email: \_\_\_\_\_  
 Phone Number: \_\_\_\_\_

		<input type="checkbox"/> COOL	<input type="checkbox"/> CSTM			Gap
Rear	1	<input type="checkbox"/>	<input type="checkbox"/>		W	Z
M1	2	<input type="checkbox"/>	<input type="checkbox"/>		W	Z
M2	3	<input type="checkbox"/>	<input type="checkbox"/>		W	Z
M3	4	<input type="checkbox"/>	<input type="checkbox"/>		W	Z
M4	5	<input type="checkbox"/>	<input type="checkbox"/>		W	Z
M5	6	<input type="checkbox"/>	<input type="checkbox"/>		W	Z
M6	7	<input type="checkbox"/>	<input type="checkbox"/>		W	Z
M7	8	<input type="checkbox"/>	<input type="checkbox"/>		W	Z
M8	9	<input type="checkbox"/>	<input type="checkbox"/>		W	Z
M9	10	<input type="checkbox"/>	<input type="checkbox"/>		W	Z
M10	11	<input type="checkbox"/>	<input type="checkbox"/>		W	Z
M11	12	<input type="checkbox"/>	<input type="checkbox"/>		W	Z
Front	13	<input type="checkbox"/>	<input type="checkbox"/>		W	Z

Make copies from this worksheet as needed and fax or email your request to us. Fax 972.436.0112 If you have any questions please call us at 1.800.657.9542 or email us at [unitherm@unitherm.com](mailto:unitherm@unitherm.com)